

## 5 Minute Datalogging Activities

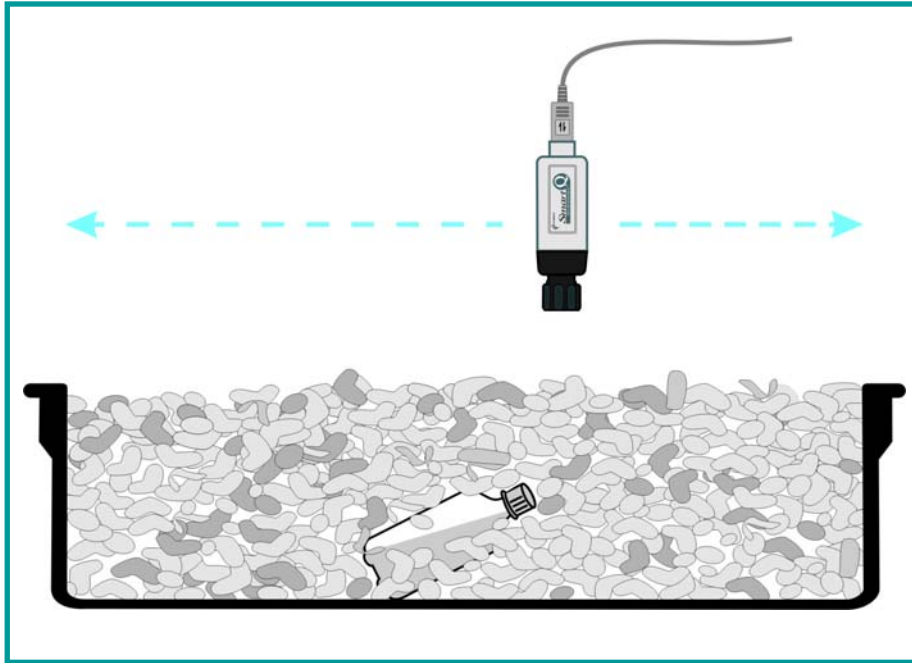

### Marketed and Distributed by:-

Data Harvest Group Ltd  
1 Eden Court  
Leighton Buzzard  
Beds. LU7 4FY  
Tel: 01525 373666  
Fax: 01525 851638  
e-mail: [sales@data-harvest.co.uk](mailto:sales@data-harvest.co.uk)  
[www.data-harvest.co.uk](http://www.data-harvest.co.uk)

Document No: **D0152**  
(Revision 1)

# Contents

# Page

01 - Temperature Race .....	1-2
02 - Cooling effect of evaporation .....	3-4
03 - Light - Transparent, Translucent and Opaque .....	5-6
04 - Muffling Sound .....	7-8
05 - Find the body! .....	9-10
06 - Thermal imaging .....	11-12
07 - Testing for Acidity .....	13-14
08 - Chemistry and Fizzy Sweets .....	15-16
09 - Cola and Alka Seltzer Reaction .....	17-18
10 - Pulse .....	19-20
11 - Heart Rate – Armchair gymnastics .....	21-22
12 - The chocolate effect! .....	23-24
13 - Breathing .....	25-27
14 - Sweating .....	28-29
15 - Transpiration: Water loss from plants .....	30-32
16 - Reaction Times .....	33-35
17 - Hit the brakes! .....	36-38
18 - Timing cars .....	39-40
19 - Measuring speeds on a runway .....	41-42
20 - Acceleration due to gravity .....	43-44
21 - Dynamo Effect .....	45-46
22 - Dropping a magnet through a wire coil .....	47-48
23 - Walk this way! .....	49-50
24 - Measuring the speed of sound in air .....	51-52
25 - Heart rate and exercise .....	53-55



Sensors: Temperature  
Logger: Any EASYSense

Logging time:  
1 minute

## 01 - Temperature Race



A simple, short activity with 2 Temperature sensors to find out who can put more energy into a temperature probe over a one-minute period. The data can then be used to explore the various analysis and display tools in the graph software.

### What you need

1. EASYSense logger.
2. 2 x Temperature sensors.
3. 2 volunteers.

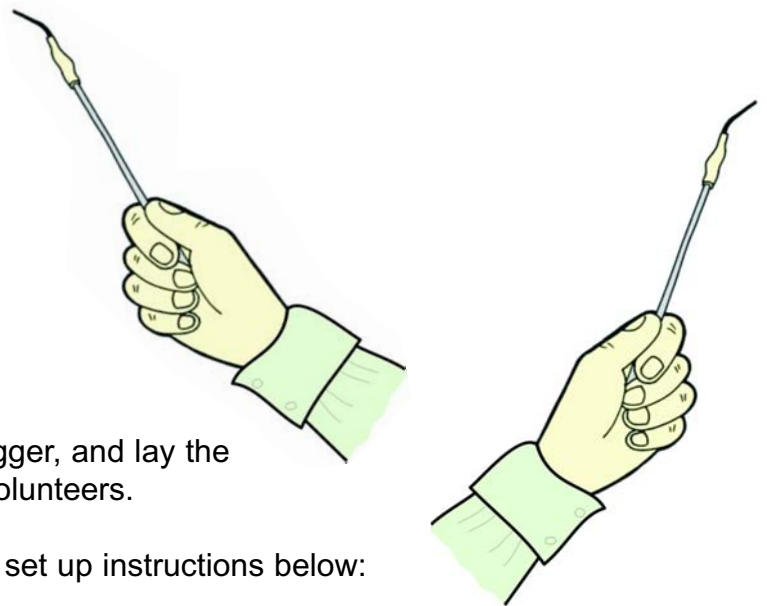

### What you need to do

1. Connect the sensors to the data logger, and lay the sensors on the bench next to the volunteers.
2. Select Graph software and use the set up instructions below:

Recording Wizard step 1	Recording Wizard step 2
Select Timespan of 1 minute	Start condition: None

3. Click on the Start icon to start the data recording.
4. Pick up the temperature sensors and hold the tip in your hand. You may warm it in any way you can think of over the next minute.



### Results

1. Use Zoom to make the graph display fill the screen.
2. Use the Values tool to explore the data and find the maximum temperature for each line.
3. Use the Interval tool from the beginning to the end of the graph to find out the difference for each person.
4. Use Area to find out the area under the graph for the first sensor.

5. Click on the sensor name on the y axis to change to the second sensor, and repeat using the Area tool.
6. Use Add text to label the graph.

## Questions

1. Is there a winner?
2. Is the graph with the highest maximum temperature, the same as the one with the greatest difference from start to finish, and the same as the one with the greatest area? If not, explain why.



Sensors: Temperature  
Logger: Any EASYSSENSE

Logging time:  
2 minute

## 02 - Cooling effect of evaporation



### Read

This is a simple experiment using 2 Temperature sensors, and introduces the use of the Overlay mode. It shows the process by which the temperature of a liquid can be changed (evaporation).

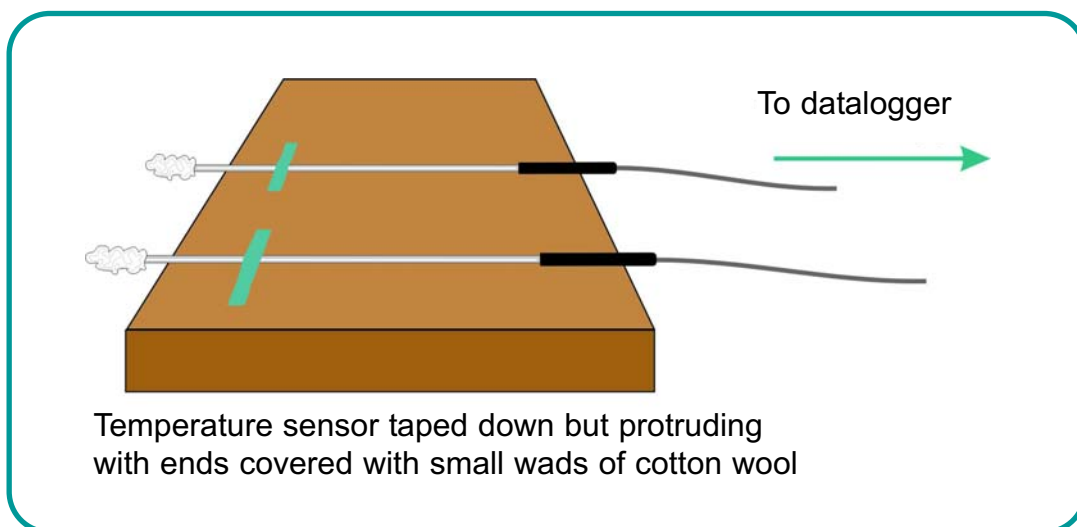

### What you need

1. EASYSSENSE logger.
2. 2 x Temperature sensors.
3. Small pieces of cotton wool, or strips of absorbent tissue.
4. Volatile liquid such as propanol, after shave or cologne.
5. Water.
6. Dropper or pipette.
7. Sticky tape to secure Temperature sensors to bench.

### What you need to do

1. Assemble the apparatus as shown in the diagram above. Use very small pieces of cotton wool wound around the end of the temperature sensors. Ensure that these pieces are almost the same size and shape.

2. Select Graph and use the set up instructions below:

Recording Wizard step 1	Recording Wizard step 2
Select Timespan of 2 minutes	Start condition: None

3. Click on the Start icon to start data logging.

4. Place 2 drops of liquid on the temperature sensor connected to input 1.

5. Leave the second sensor dry as the control.



## Results

1. Use Auto scale or Zoom to make the graph display fit the screen.

2. Use Values to explore the changes during the experiment.

3. Use the Interval tool to find out how much the temperature changed from the maximum to the minimum temperature value.

4. Use Add text to label the sets of data.

5. The results can be saved, printed or copied into your report document.

## Questions

1. What was the temperature change for the liquid you measured?

2. Apart from the temperature change, how could you tell that the liquid was evaporating?

## Extensions

Replace the cotton wool pieces and repeat with other liquids, including water.



Sensors: Light level 0-1000lux  
Logger: Any EASYSense

Snapshot logging

## 03 - Light - Transparent, Translucent and Opaque



This activity introduces the Snapshot table and uses the Light sensor (0 – 1000 lux) to measure the amount of light blocked by a variety of materials.

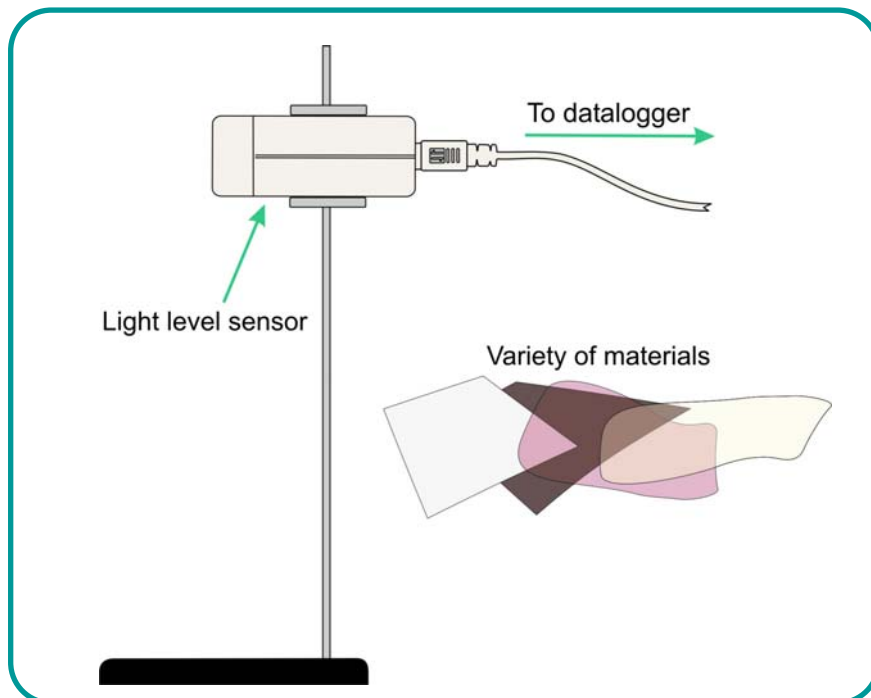

### What you need

1. **EASYSense** logger.
2. 1 x Smart Q Light level sensor (0 – 1000 lux).
3. Light source (torch or mains lamp).
4. Variety of materials (transparent, translucent and opaque materials e.g. clear polythene, coloured film, paper or card).

### What you need to do

1. Set up the apparatus as shown above.
2. Select Snapshot.

3. Click on the Start icon to begin.
4. Click in the graph area to take the first measurement with no material between the light and sensor – the control.
5. Double click in the Comments column and enter what you have measured.
6. Place a sample material in front of the light source, and take snapshot reading, entering details in the Comments column each time.
7. Repeat until all the samples have been tested.
8. Click on stop.



## Results

Use the Add tool to put labels on the bar graph, marking the results as Translucent, Transparent or Opaque.

## Questions

Explain what the terms translucent, transparent and opaque mean?



Sensors: Sound  
Logger: Any EASYSense

Logging time:  
20 seconds

## 04 - Muffling Sound



This activity introduces the sound sensor and the concept that sound travels through some materials better than others and that some materials are better sound insulators than others.

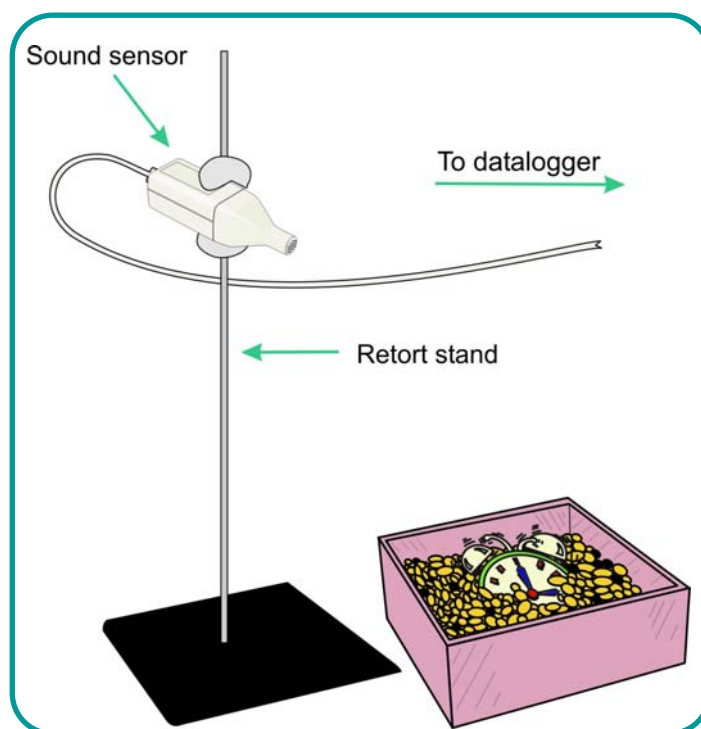
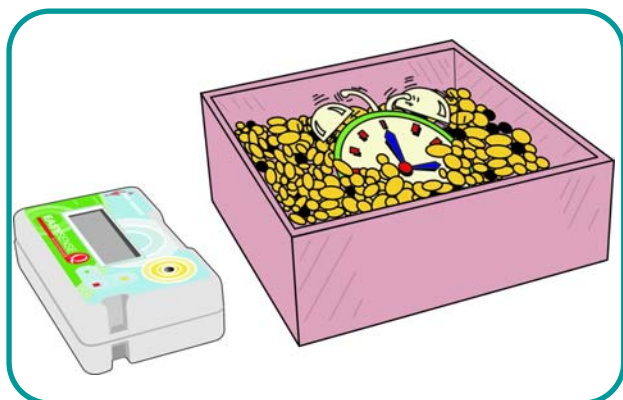

### What you need

1. EASYSense logger.
2. 1 x Smart Q Sound sensor.
3. Large box and a variety of materials e.g. crumpled newspaper, polystyrene chips, fabric, wadding, bubble wrap.
4. Noise maker e.g. Alarm clock.

### What you need to do

1. Set up apparatus as shown.
2. Select Graph and set up as below:

<b>Recording Wizard step 1</b>	<b>Recording Wizard step 2</b>
Select a Timespan of 20 seconds	Start Condition: None

3. As a control, make the first recording without any noise maker.
4. Click on the Start icon to start the data logging.
5. Select Overlay mode, bury the noisy clock in the first chosen material in the box.
6. Click on the run icon to start the data logging.
7. Repeat with other materials.



## Results

1. The graph can be saved, printed or copied into a report document.
2. Use the Add tool to show which material produced which graph.

## Questions

1. Which material was best at muffling sound?
2. Which was the worst at muffling sound? Explain why you think this might be.



Sensors: Infra red (without filter)  
Logger: Any EASYSense

Logging time:  
20 seconds

## 05 - Find the body!



This activity introduces the infra red sensor and its ability to measure radiated heat as energy, in a dramatic way.

Rescue workers operating from helicopters, when seeking living persons buried under rubble may use an infra red device to locate warm areas, so that those on the ground know where to dig. In this activity, a box of polystyrene chips represents rubble, and the challenge is to find the body.

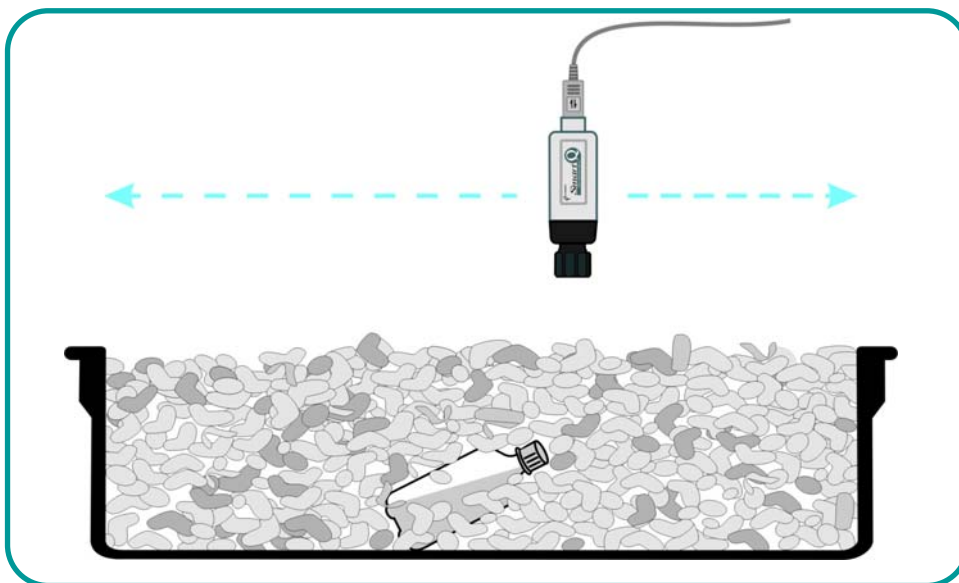

### What you need

1. EASYSense logger.
2. 1 x Smart Q Infra red sensor – set to its lowest range  $30W/m^2$ .
3. Box of polystyrene chips (or crumpled newspaper).
4. Small sealed bottle of hot water.
5. Several small flags to act as markers.

## What you need to do

1. Set up the apparatus as shown in the diagram above and hide the bottle under the 'rubble'.
2. Select Meters and make the Numbers screen full screen.
3. Scan the surface of the 'rubble' to locate the body – the measurements will rise significantly if a hot body is detected.
4. Mark the 'hot' area with flags.
5. Dig the marked area to see if the 'body' is there.



Sensors: Infra red (without glass filter)  
Logger: Any EASYSense

Logging time:  
20 seconds

## 06 - Thermal imaging



This simple activity introduces the infra red sensor and its ability to measure radiated heat as energy. NASA satellites use infrared sensors to create a thermal image of the earth. We will produce a graph of the residual heat radiated from a hand print on the laboratory bench.

### What you need

1. EASYSense logger.
2. 1 x Smart Q Infra red sensor – set to its lowest range  $30\text{W}/\text{m}^2$ .

### What you need to do

1. Rest the palm of your hand on the bench, as though in the centre of a  $20\text{cm} \times 20\text{cm}$  square.

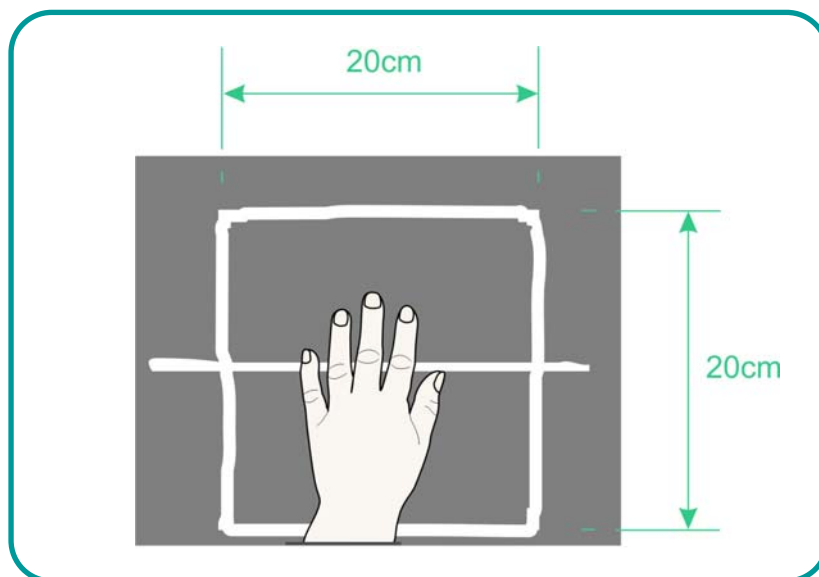

2. Select EasyLog.
3. Remove your hand and press the Start icon to start the data logging.
4. Use the infrared sensor to scan slowly along the bench as shown in the Fig. b to record the residual heat.
5. Click Stop to finish recording.

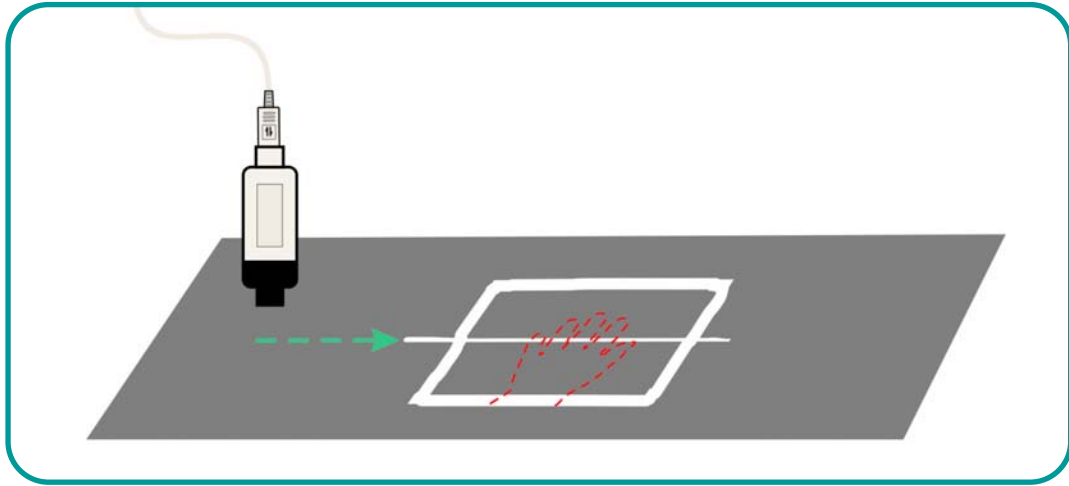

## Results

1. Use Autoscale to make the graph display fill the screen.
2. Use Add Text to label the graph – first finger, thumb etc.

## 07 - Testing for Acidity



This activity introduces the pH sensor, as a more sensitive method of finding out whether a solution is acid, alkaline or neutral, and the use of Snapshot, to record individual readings for comparison.

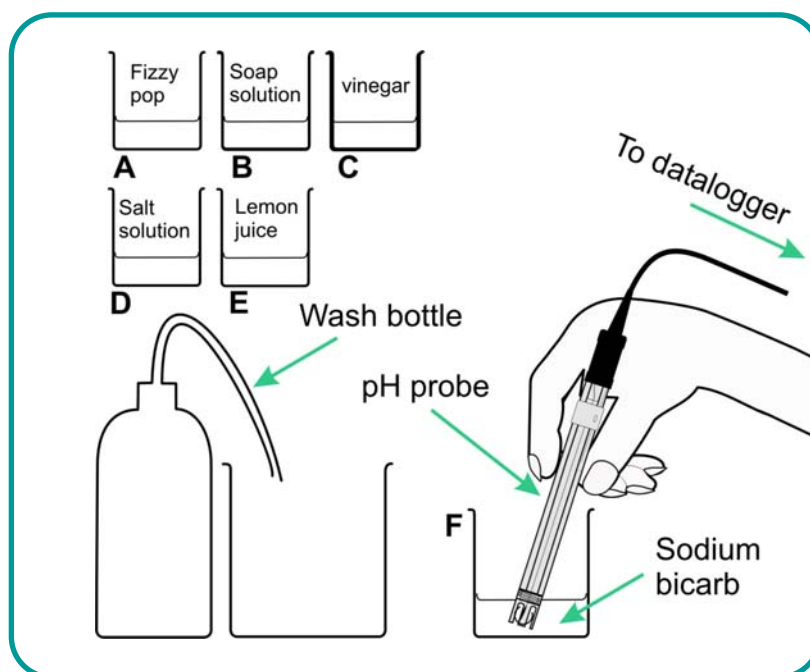

### What you need

1. **EASYSense** logger.
2. 1 x pH Adapter and Electrode.
3. 6 beakers and various solutions to test e.g. fizzy pop, soap solution, vinegar, salt solution, lemon juice and sodium bicarbonate.

### What you need to do

1. Connect the pH probe to the data logger.
2. Select Snapshot.
3. Carefully put the pH probe into solution A, and read the pH value from the screen.

4. Click on the graph area to record the pH value for solution A.
5. Double click in the Comments cell alongside the reading to enter the name of the solution.
6. Rinse the probe carefully in water, then repeat steps 3 – 5 for all the other solutions.
7. Click on Stop to stop recording.



## Results

You can save, print or copy and paste your results into your report document.

## Questions

1. pH values range from 1 to 14. Find out what the pH values are for acid solutions, alkaline solutions and neutral solutions.
2. Use this information to decide what type of solutions A, B, C, D, E and F are. Write your decision alongside your results.
3. Explain why the pH probe is washed before using it in different solutions.



Sensors: Temperature  
Logger: Any EASYSense

Logging time:  
2 minutes

## 08 - Chemistry and Fizzy Sweets



This experiment uses the Temperature sensor to measure a small change during a chemical reaction.

Some primary children in Staffordshire completed a Tuck Shop survey and found that Sherbet Fountains and other fizzy sweets sold well in the summer, but hardly at all in the winter. They wanted to test why this should be, so set up the following experiment.

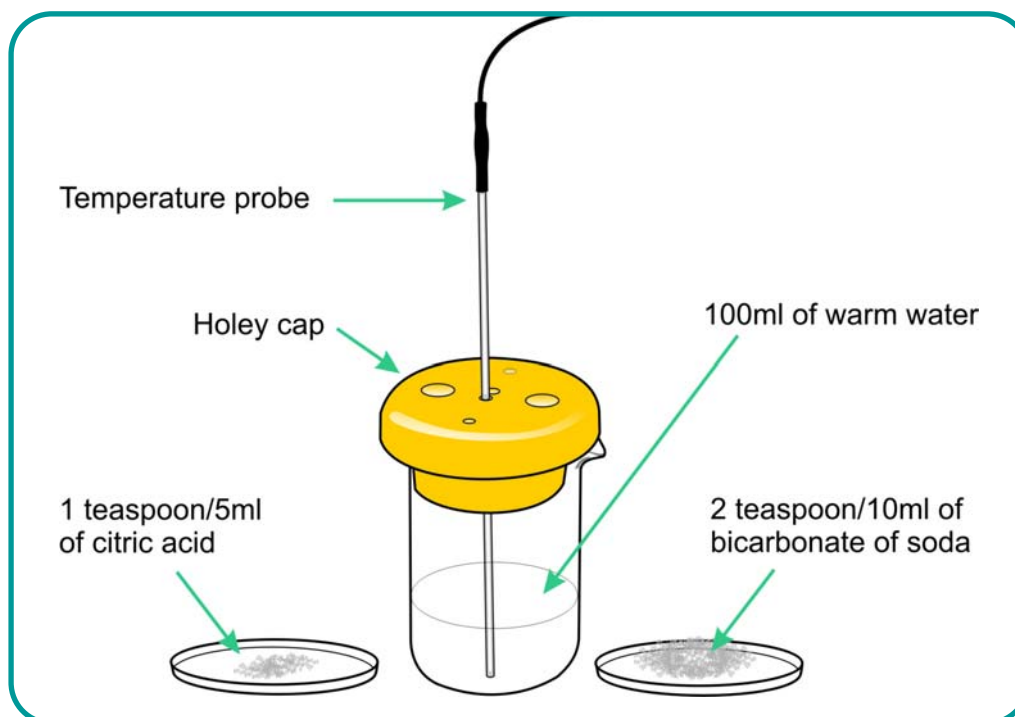

### What you need

1. EASYSense logger.
2. 1 x Smart Q Temperature sensor.
3. Beakers – 250 ml.
4. Warm water (37°C approx. to simulate mouth temperature).
5. 1 teaspoon/5ml of citric acid.
6. 2 teaspoons/10 ml of bicarbonate of soda.

## What you need to do

1. Select Graph, and use the set up details below.

Recording Wizard step 1	Recording Wizard step 2
Select Timespan 2 minutes	Start Condition: None

2. Pour 100ml warm water into a beaker and position the temperature sensor.
3. Click on the Start icon to start data logging.
4. Add the bicarbonate of soda, stir with the temperature probe, then add the citric acid and stir. (It will fizz wildly at first.)



## Results

1. Use the Values tool to read the values from the graph.
2. Use Autoscale to make the data fill the screen.
3. Use the Interval tool to find out how much the temperature changed during the experiment.
4. You may save the data, print the graph, or copy and paste it into your report document.

## Questions

By how much did the temperature of the water change from the start to the end of the fizz?

## 09 - Cola and Alka Seltzer Reaction



This easy activity introduces the pH sensor, and the overlay mode in Graph.

Alka Seltzer tablets are taken to neutralise an acid stomach. In this experiment, you will use cola to represent an acid stomach, and compare the effect of a solid tablet, with a crushed tablet.

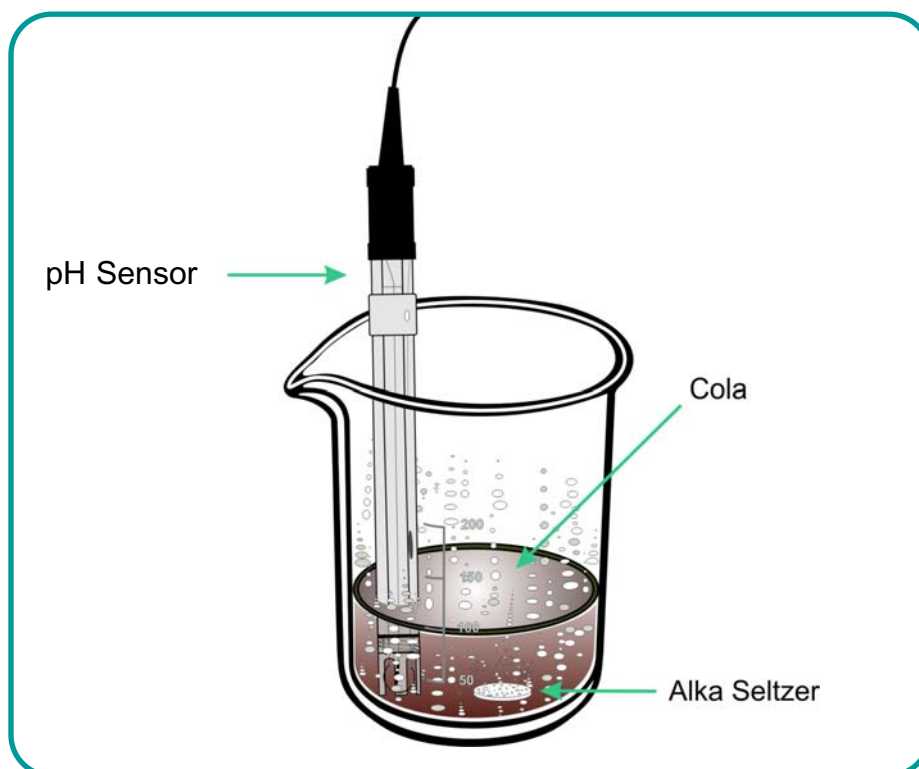

### What you need

1. **EASYSense** logger.
2. 1 x Smart Q pH Adapter and Electrode.
3. Beakers 250 ml.
4. ½ Alka Seltzer tablet - solid.
5. ½ Alka Seltzer tablet - crushed.

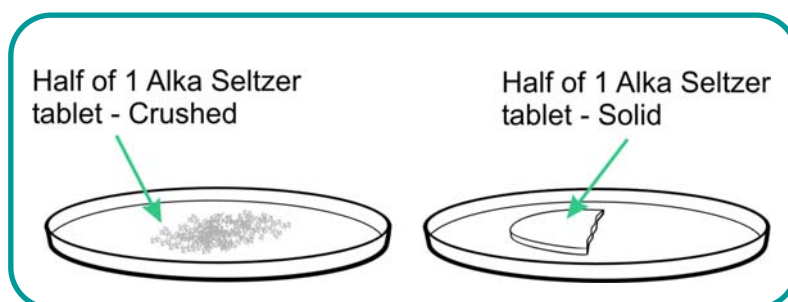

## What you need to do

1. Set up the apparatus as shown in the diagram above.
2. Position the pH sensor in the 100ml cola.
3. Select Graph software and use the set up below.

Recording Wizard step 1	Recording Wizard step 2
Select Timespan 2 minutes	Start Condition: None

4. Click on the Start icon to start data logging.
5. Add the solid Alka Seltzer tablet.
6. When the logging has finished, click on Overlay mode.
7. Wash the pH sensor in water.
8. Pour 100 ml cola into a clean beaker, and position the pH probe in the liquid.
9. Click on the Start icon to start data logging.
10. Add the crushed Alka Seltzer tablet, stirring with the pH probe.



## Result

1. You can save, print or copy and paste the graph into your report document.
2. Use Zoom or Autoscale to make the graph display fill the screen.
3. Use Add text to label the graph to show, which line the solid tablet produced, and which the crushed tablet produced.
4. Use the Gradient tool to determine the rate of reaction.

## Questions

Can you explain why there is a difference between the rate of these reactions?



Sensors: Pulse / Heart Rate  
Logger: Any EASYSense

Logging time:  
10 seconds

# 10 - Pulse



This quick activity introduces the pulse waveform range of the heart rate sensor, and is the ideal introduction to any heart rate investigation.

## What you need

1. EASYSense logger.
2. 1 x Smart Q Heart Rate sensor – select pulse waveform range.

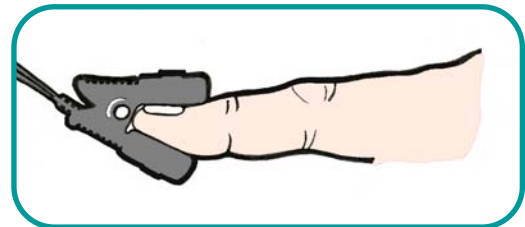

## What you need to do

1. Connect the heart rate sensor to input 1 of the EASYSense logger and load Sensor Config program to set the sensor range.
2. Set the heart rate sensor's range to pulse waveform, and exit Sensor config.
3. Clip the sensor on to your finger, or to your ear lobe and check that the LED on the sensor is flashing on and off.
4. Select Graph software and set up the recording as below:

Recording Wizard step 1	Recording Wizard step 2
Select a Timespan of 10 seconds	Start Condition: None

5. Stay still and click on the Start icon to start data logging.
6. Click on Overlay mode and repeat with another volunteer.



Showing one graph at a time, count the number of peaks and multiply by 6 to find out how many times your heart beats per minute.

Use Add text to note your heart rate in beats per minute.

Repeat step 1 and 2 for all the graphs.

## Extension activity

Repeat this activity after exercise to compare resting heart rate with exercising heart rate.

**Note:** There is a wide variation in people's heart rates.

Children and adults with cold hands should rub their hands to improve the blood circulation before this activity.





# 11 - Heart Rate – Armchair gymnastics



This activity introduces the Heart Rate sensor, which clips either to your index finger or to your ear lobe. This simple heart rate sensor works well as long as it is kept still, and you are indoors.

## What you need

1. EASYSense logger.
2. 1 x Heart rate sensor.

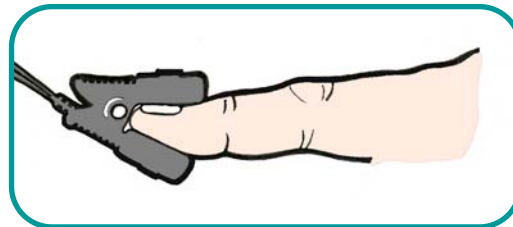

## What you need to do

1. Set up the sensor and check that the LED is flashing on and off steadily.
2. Select Graph software and use the set up instructions below:

Recording Wizard step 1	Recording Wizard step 2
Select a Timespan of 2 minutes	Start Condition: None

3. Sit comfortably, then click on the Start icon to start data logging.
4. Stay still for 20 seconds, then raise your right hand for 20 seconds.
5. Lower your right hand and stay still for 20 seconds.
6. Without moving your left hand, stand up and stand still for 20 seconds.
7. Raise your right hand and wave it around for 20 seconds.
8. Lower your right hand and sit down and stay still until the recording finishes.

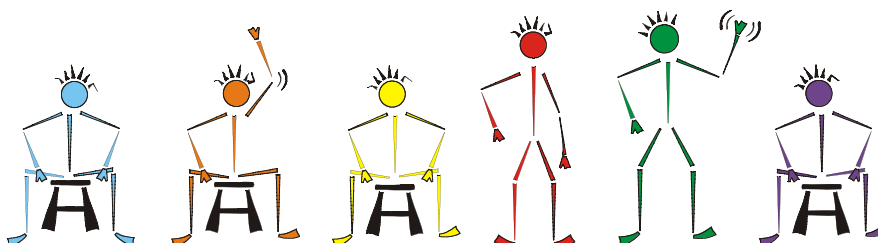



## Results

1. Use Zoom or Autoscale to make the graph display fill the screen.
2. Use Add text to label the different activities.

## Questions

1. Does your heart always beat at the same rate?
2. When did your heart beat fastest?
3. What was your heart rate at the start?
4. Was your heart rate at the end, the same as at the start?



Sensors: Pulse / Heart Rate  
Logger: Any EASYSense

Logging time:  
5 minutes

## 12 - The chocolate effect!



This is a fun activity based on the heart rate sensor. We know that our heart rate alters as we exercise, but this activity explores something else that can alter our heart rate – eating chocolate!



### What you need

1. EASYSense logger.
2. 1 x Smart Q Heart Rate sensor.
3. Chocolate (With a wrapper that rustles; it works better if it is obvious what they are getting!).

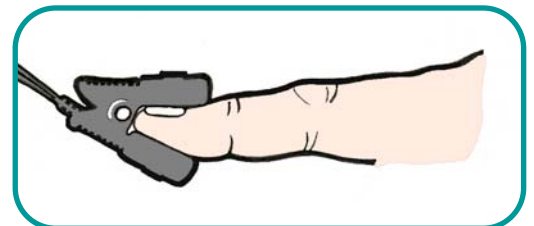

### What you need to do

1. Connect the heart rate sensor to the index finger of your left hand, or to your ear lobe and check that the LED is flashing on and off steadily. Keep your finger still.
2. Select Graph software, and use the set up below.

Recording Wizard step 1	Recording Wizard step 2
Select a Timespan of 5 minutes	Start Condition: None

3. Click on the Start icon to start data logging.

4. Sit quietly for 30 seconds, to record your resting heart rate.
5. Take a bite of chocolate. Enjoy!
6. Let the heart rate return to its resting rate.
7. Take a second bite of chocolate.



## Results

1. Use Zoom or Autoscale to make the data fit the screen.
2. Use Smooth, if necessary.
3. Use the Values tool to read the information from the graph.

## Questions

1. By how much did your heart rate change when you were eating chocolate?
2. Did your heart rate change as much during the second bite of chocolate.

## Extension activity:

Try another stimulant e.g. caffeine in Cola or Red Bull, or hot drinks such as tea and coffee.



Sensors: Oxygen Adapter and Electrode  
Logger: Any EASYSSENSE

Logging time:  
1 minute

# 13 - Breathing



This activity introduces the oxygen sensor measuring the oxygen content of air. You will find out how much oxygen is consumed when you breathe in and out whilst sitting quietly. You may go on then and compare the result with the oxygen consumed after a short burst of exercise.

## What you need

1. EASYSSENSE logger.
2. 1 x Smart Q Oxygen Adapter and Electrode.
3. Medium sized polythene, or paper bag (to breathe into).

## What you need to do

### Part 1 – Setting up and calibrating the oxygen sensor

1. Set up the oxygen electrode. Fill the cap with electrolyte and screw it on to the electrode. Connect the electrode to the adapter, and the adapter to the EASYSSENSE logger.
2. Leave the oxygen sensor in a vertical position for approximately 5 minutes to settle.
3. Start the Sensor Config programme to ensure the Oxygen sensor is set for 0 – 25% O<sup>2</sup> Air. Alternatively use the System menu on EASYSSENSE to set sensor range.
4. Select Graph and use Test to check the oxygen value. If the readings are stable (not falling), calibrate the oxygen sensor to read 21% by turning the black knob on the adapter. The oxygen sensor is now ready to use.

### Part 2 – The experiment

1. Click on New.

<b>Recording Wizard step 1</b>	<b>Recording Wizard step 2</b>
Select a Timespan of 1 minute	Start Condition: None

2. Click on the run icon to start data logging.



3. Take a deep breath.
4. With the oxygen sensor held vertically in the bag, breathe out slowly into the bag and hold the bag shut.
5. When the data recording has finished, remove the oxygen sensor from the bag, and keep it vertical.



## Results

1. The graph may be saved, printed or copied into your report document.
2. Use the Values tool to find the minimum value.
3. Use Add text to label the lowest value.
4. Use the Interval tool to find out how much oxygen was consumed during one breath.

## Questions:

1. How much oxygen did you consume during one breath?
2. What other gases are exhaled when you breathe out?

## Extensions

1. Results and analysis.
2. The graph line shows a change in oxygen level.

3. Use the Values tool to find the lowest value.
4. Use the Interval tool to find out the change from the start to the lowest value.

## Questions

1. How much difference was there between the start of the graph line and the lowest value?
2. Repeat this experiment, after a period of exercise (running up and down stairs for instance) to find out whether there is a difference in the results.

## Extension activity

Do some vigorous activity – e.g. running up and down stairs, Stepping, Exercise bike, then repeat the activity and compare the results.



Sensors: Humidity  
Logger: Any EASYSense

Logging time:  
2 minutes

## 14 - Sweating



This activity introduces the Humidity sensor, and the use of the Overlay mode for repeated experiments. The humidity sensor with its plastic chamber when placed against the skin records the change of humidity caused by transpiration, otherwise known as sweating. Once this effect has been experienced, you are ready to investigate whether antiperspirants are effective.

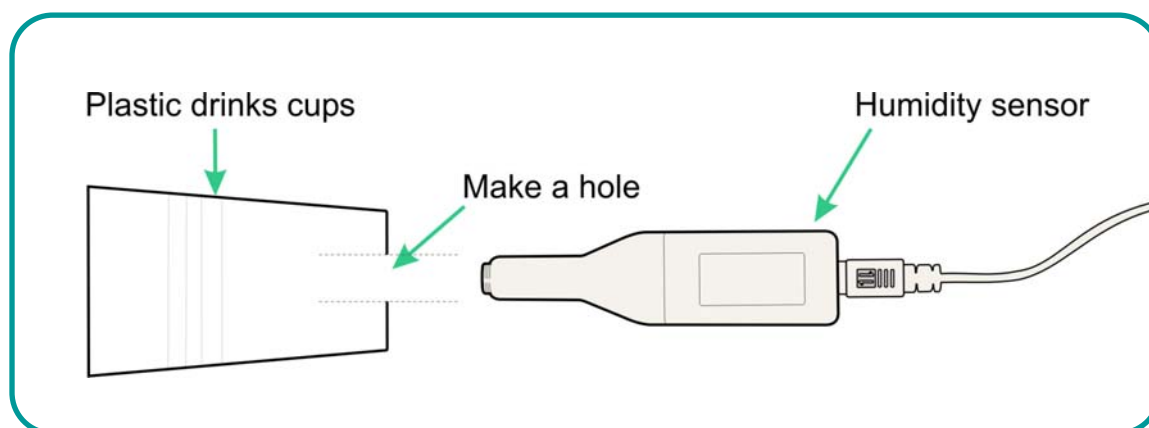

### What you need

1. EASYSense logger.
2. 1 x Smart Q Humidity sensor.
3. 1 Plastic drinks cup (e.g. from water cooler) prepared as shown.
4. Range of products to test e.g. Deodorant – roll on liquid, or cream and Antiperspirant - roll on liquid, or cream.

**Hazard Information:** Do not apply products to broken skin. If you know you are sensitive to any of the products being presented, be sensible and do not use them on yourself.

### What you need to do

1. Prepare the apparatus as shown.
2. Select Graph software and set up a recording as below.

Recording Wizard step 1	Recording Wizard step 2
Select a Timespan of 2 minutes	Start Condition: None

3. Press Start to record the humidity in the room.
4. Place the open end of the cup firmly either against the palm of your hand, or against the inner lower arm.
5. When the recording has finished, select Overlay mode, so that subsequent lines are recorded on the same axes.
6. Apply antiperspirant to the skin. Check that the humidity level has returned to the room level.
7. Press Start , placing and holding the cup firmly over the area where antiperspirant has been applied.



## Results

1. Use Zoom or autoscale to ensure that graph display fills the screen.
2. Use Add text to label each trace, room, skin, antiperspirant.
3. Use the Values tool to explore the data.
4. Use the Gradient tool to compare the rate of change of each line. Remember to click on Humidity at the top of the Y axis to scroll through the different recordings.

## Questions

Which product performed best? Explain your answer.



Sensors: Humidity  
Logger: Any EASYSense

Logging time:  
2 minute

## 15 - Transpiration: Water loss from plants



This experiment uses the Humidity sensor to compare transpiration from leaves of different plants.

Transpiration is the engine by which water is drawn through the plant and up into the leaves. Plants use the water for photosynthesis and structural support. A lack of water will lead to wilting of the plant. Some plants wilt in the midday sun as a protection against water loss e.g. Beet plants.

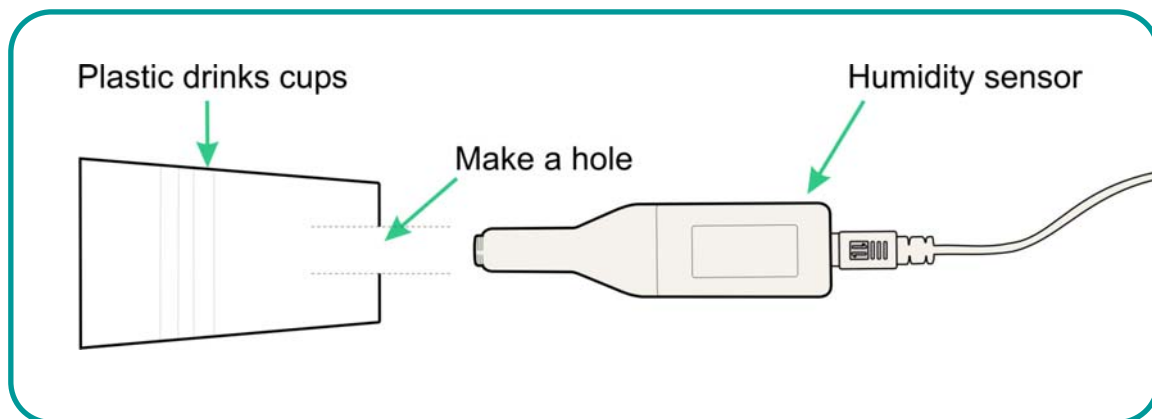

### What you need

1. EASYSense logger.
2. 1 x Smart Q Humidity sensor.
3. 2 Beakers and 1 plastic beaker with hole in the base.
4. 2 x Card discs with hole in the centre, or cling film.
5. Several leaves of similar size.

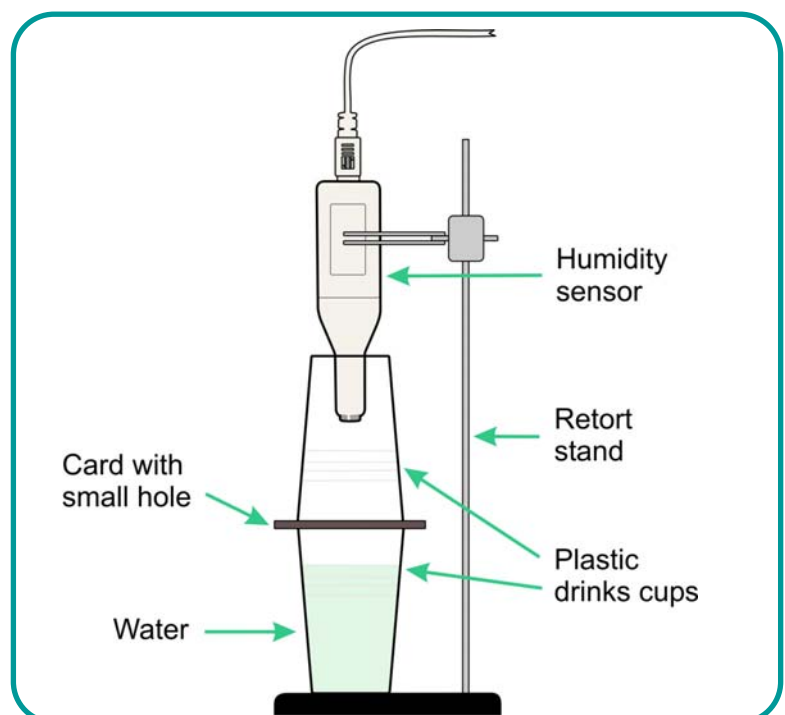

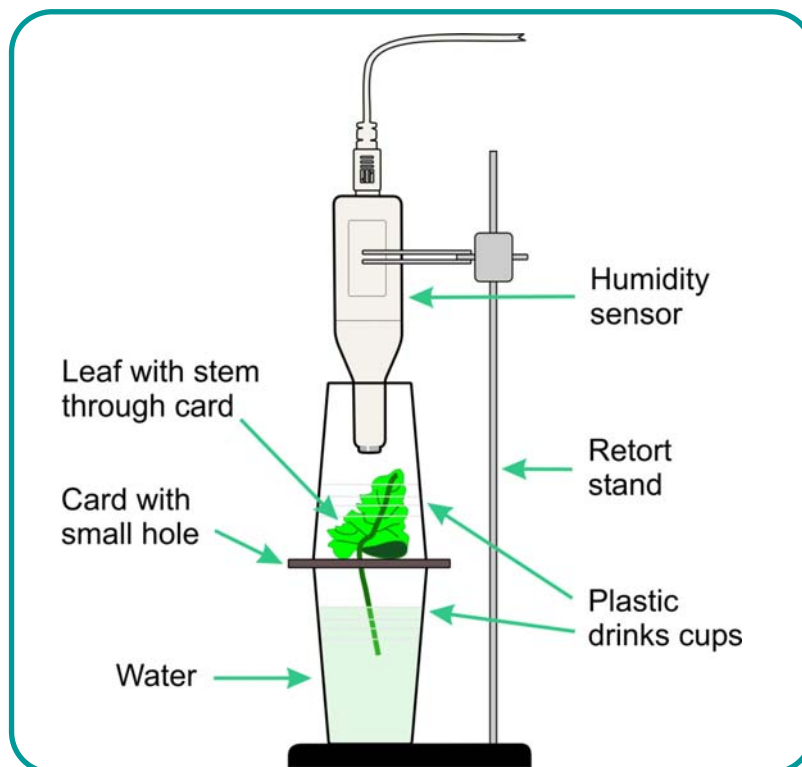

## What you need to do

1. Assemble the apparatus as the diagram above. If cling film is used, make a small hole in the centre, though which the leaf stem can be placed.
2. Select Graph software, and use the set up below.

Recording Wizard step 1	Recording Wizard step 2
Select a Timespan of minutes	Start Condition: None

3. Before positioning the humidity sensor, use Test mode to check the normal reading in the room.
4. Place the Humidity sensor and upper chamber over the control set up and click on the Start icon to start data logging.
5. At the end of the recording, remove the upper chamber and allow the Humidity sensor to return to normal room reading (approx 3 – 4 minutes).
6. Ensuring Overlay mode is selected, place Leaf 1 in the second beaker, position the humidity sensor and upper chamber, then click on the Start icon to start a second graph.
7. Repeat steps (5) and (6) again to test leaves 2 and 3.



## Results

From the resulting set of graphs extract the information required to complete the table below, using the Values tool and the Interval tool:

Leaf type	Lowest humidity	Highest humidity	Difference between lowest and highest humidity reading

## Questions:

1. How does the size of the leaf change how quickly the humidity changes inside the chamber?
2. Does the type of leaf have any effect on how quickly the humidity changes inside the chamber?

## Extensions

1. Investigate the effect of light on the rate of transpiration, using the same set up.
2. Investigate from which side of the leaf transpiration is greater, using the same set up. You will require 3 identical leaves. Smear Vaseline on the top surface of one leaf, on the lower surface of the second leaf, leaving the third clear.
3. Investigate whether the transpiration rate is the same for different types of leaf e.g. shiny leaves, silver leaves, hairy leaves etc.
4. Does the colour of the light have any effect. Place a coloured filter (gel) between the light and the leaf. Which colour has most effect?



Sensors: Push Button Reaction Switch  
Logger: Any EASYSense

Logging time:

## 16 - Reaction Times



This investigation will look at reaction times and factors that may alter them. A reaction time is the quickest time an individual can respond to a stimulus.

### What you need

1. EASYSense logger.
2. 2 X Smart Q Push Button Reaction Switch. (One of which must have an LED).
3. Various items to use as distractions e.g. sound source (Walkman), mobile telephone.

### What you need to do

The tester presses the Smart Q switch with the LED, and the responder pushes the second Smart Q switch as soon as he/she see the LED flash on. This produces a timed response and the software records the reaction times as metres per second.

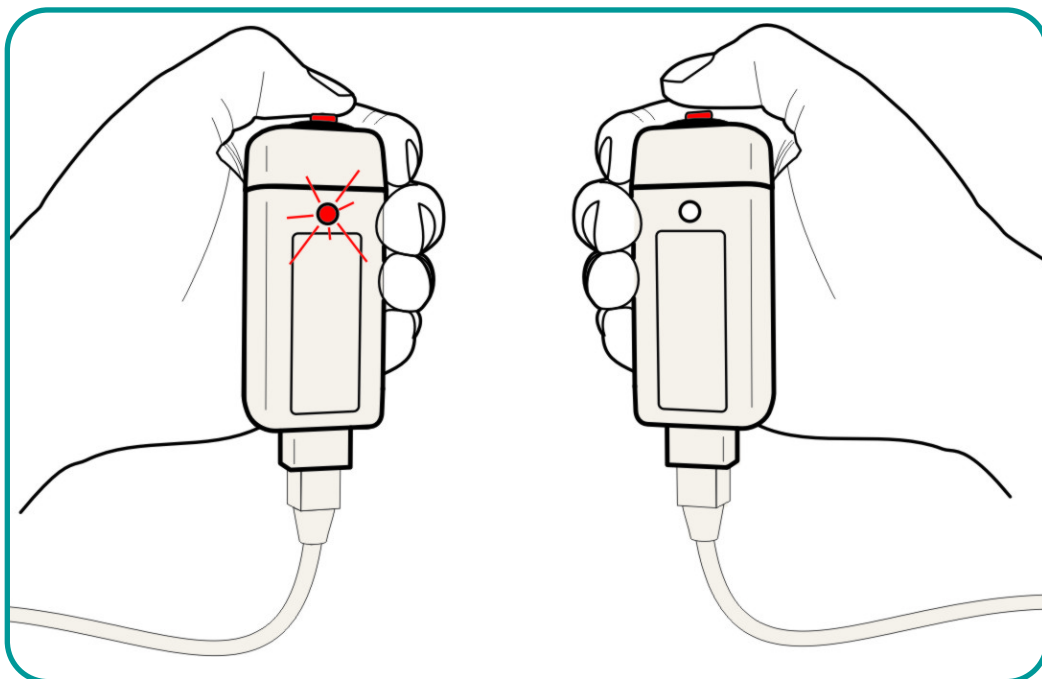

Select Timer and set up as shown below.

Recording Wizard step 1	Recording Wizard step 2
Time and speed	Time and speed from A to B
	$A - B =$ the distance from eye to thumb tip

You should measure the distance from the responder's eye to thumb tip and use this as the distance from A to B. (The distance from the LED to the eye is of no concern in this experiment.)

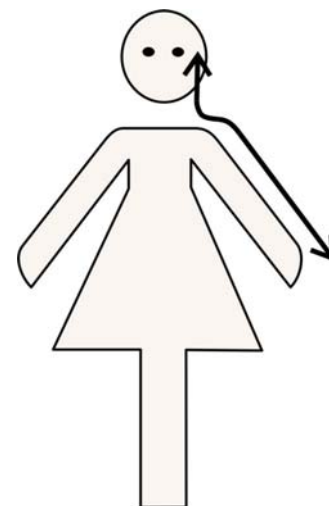

1. Set up the apparatus as shown in the diagram above, making sure the responder cannot see any movement of the tester's hand or fingers.
2. Make sure the responder is ready for the test. (Suggest giving them a few test runs to get used to the experiment.)
3. Press the Start icon to start data logging.
4. Tester presses the switch with LED on, and keeps light on until the response is seen on the screen.
5. When recording has stopped. Click on Analysis, show statistics to find average (mean).

## Extensions

1. Let the responder listen to some music on a pair of headphones and repeat the experiment.
2. Let the responder listen to a tape of instructions that need following and repeat the test.
3. Let the responder have a drink containing caffeine, e.g. Cola or coffee to see if the reaction times vary.



The results will be presented as time from A to B and a speed. This gives a direct value of the speed of reaction. Be aware of the range of the time scale used, as it is normal to express reaction times as tenths or hundredths of a second.

The table of results can be printed or use copy and paste to transfer it to a document. Copying into Excel (or similar spreadsheet) will enable mathematical calculations to be undertaken on this data.

## Questions

1. How does your reaction time compare to the values printed in textbooks or on the web?

2. Collect the averages for the rest of the group, or class. Calculate the average for the class. How many people fall below the average? Is there a difference between genders, calculate the average for female, and average for male responders?
3. Find out about stopping distances from a textbook. Knowing your reaction times, how far will you travel before stopping using the stopping values in the Highway Code at 30 mph, 40 mph and 50 mph.
4. The test using taped instructions simulates a phone call when driving, how did this test affect the reaction time and ultimately the stopping distance.
5. If you have access to a scientific calculator and have sufficient data, you can do a statistical test called standard deviation. If you calculate the s.d. this will allow you to compare data from other reaction time experiments with more certainty.

## Identifying errors

1. Make a list of the possible sources of error in this experiment, and then attempt to quantify the errors in terms of how much they have affected the results?
2. Discuss the errors identified with others to see if they are realistic or come from preconceived ideas about reaction times.

## Notes on Standard Response

The gap between two neurons ( the synapse) has physical properties that introduce a time delay (latency) of approx. 10ms per synapse. The neuron can carry the message at a maximum speed of 30 metres per second. Taking both these factors into consideration, it would be unlikely to see a reaction time of below .02 seconds.



Sensors: Push Button Reaction Switch, Timing Mat  
Logger: Any EASYSense

Logging time:  
Timer

## 17 - Hit the brakes!



This 'reaction time' investigation provides a simple model for the time taken to depress the brake pedal of a car, after the stimulus.

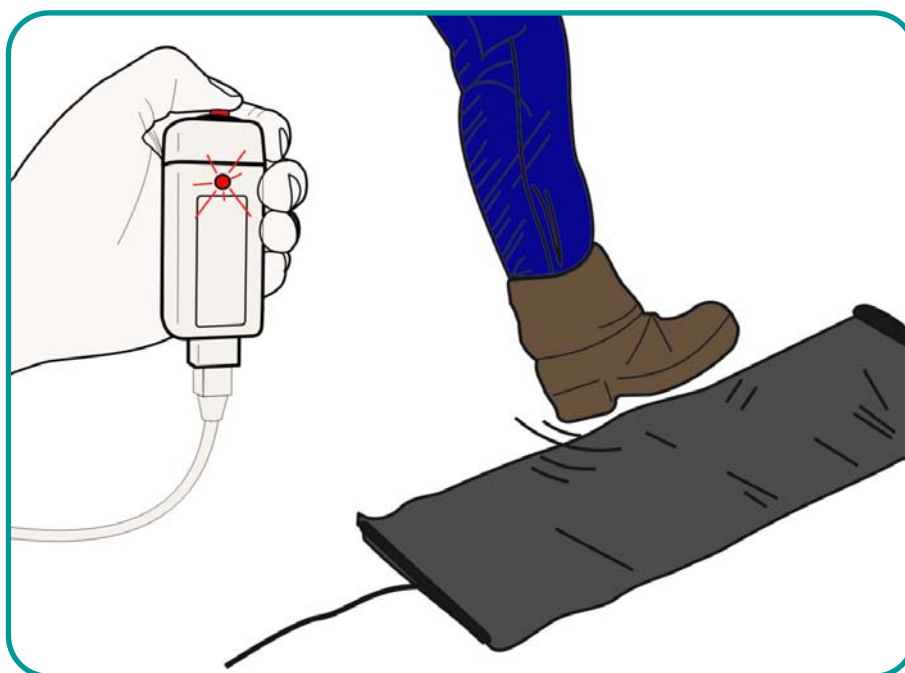

### What you need

1. EASYSense logger.
2. 1 x Smart Q Push Button Reaction Switch with an LED fitted.
3. 1 x Smart Q Timing Mat.
4. Various items to use as distractions e.g. sound source (Walkman), mobile telephone.

### What you need to do

The reaction times are recorded by the tester pressing the Smart Q switch with the LED, and the responder pressing his or her foot on the timing mat to produce a timed response. The Timer program is used to display the results.

You should measure the distance from the responder's eye to sole of foot and use this as the distance from A to B. (The distance from the LED to the eye is of no concern in this experiment.)

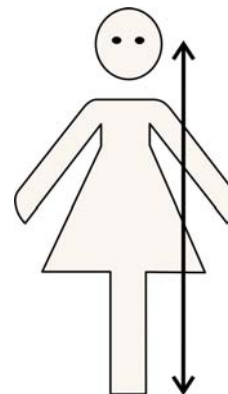

1. Set up the apparatus as shown in the diagram above, making sure the responder cannot see any movement of the tester's hand or fingers.
2. Launch the Timer program, and use the set up below.

Recording Wizard step 1	Recording Wizard step 2
Time and speed	Time and speed from A to B
	Enter distance from eye to sole of foot

3. Make sure the responder is ready for the test. (Suggest giving them a few test runs to get used to the experiment.) The responder may need to stand in order to exert sufficient pressure on the timing mat.
4. Press the run icon to start data logging.
5. Tester presses the switch with LED on, and keeps light on until the response is seen on the screen.
6. When recording has stopped. Click on Analysis, show statistics to find average (mean).

## Extensions

Let the responder listen to some music on a pair of headphones and repeat the experiment.

Let the responder listen to a tape of instructions that need following and repeat the test.

Let the responder have a drink containing caffeine, e.g. Cola or coffee to see if the reaction times vary.

Compare the reaction time by "hitting the breaks" to the simple "see the light hit the switch" test.



## Results

The results will be presented as time from A to B and a speed. This gives a direct value of the speed of reaction. Be aware of the range of the time scale used, as it is normal to express reaction times as tenths or hundredths of a second.

The table of results can be printed or use copy and paste to transfer it to a document. Copying into Excel (or similar spreadsheet) will enable mathematical calculations to be undertaken on this data.

## Questions



1. How does your reaction time compare to the values printed in textbooks or on the web?
2. Collect the averages for the rest of the group, or class. Calculate the average for the class. How many people fall below the average? Is there a difference between genders, calculate the average for female, and average for male responders?
3. Find out about stopping distances from a textbook. Knowing your reaction times, how far will you travel before stopping using the stopping values in the Highway Code at 30 mph, 40 mph and 50 mph.
4. The test using taped instructions simulates a phone call when driving, how did this test affect the reaction time and ultimately the stopping distance.
5. If you have access to a scientific calculator and have sufficient data, you can do a statistical test called standard deviation. If you calculate the s.d. this will allow you to compare data from other reaction time experiments with more certainty.

## Identifying errors

1. Make a list of the possible sources of error in this experiment, and then attempt to quantify the errors in terms of how much they have affected the results?
2. Discuss the errors identified with others to see if they are realistic or come from preconceived ideas about reaction times.



Sensors: Light gates  
Logger: Any EASYSSENSE

Logging time:  
Timing

## 18 - Timing cars



This investigation introduces the use of 2 light gates to record accurately the time taken for a car to travel from light gate A to light gate B. The software also calculates the speed from A to B.

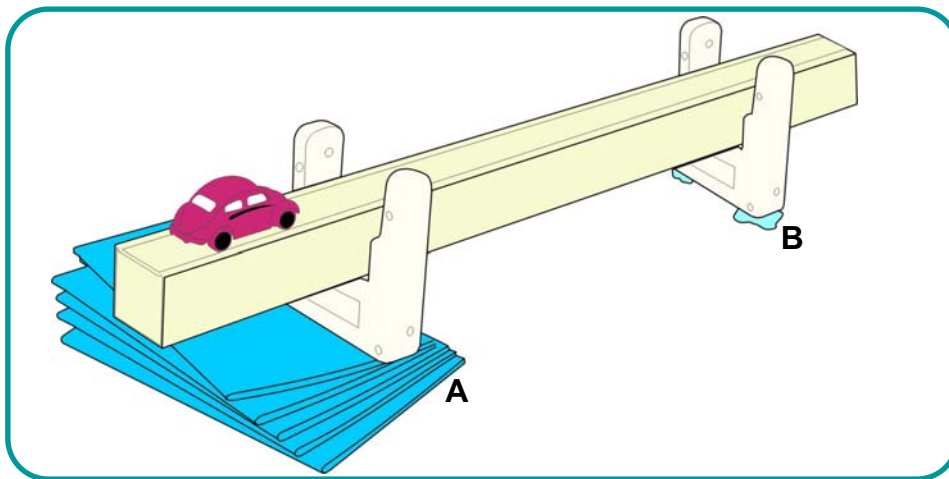

### What you need

1. EASYSSENSE logger.
2. 2 x Smart Q Light gates.
3. Inclined plane and a selection of toy cars.

### What you need to do

The light gate A starts timing when the car breaks the beam. The Light gate B stops timing when the car breaks the beam. Make sure A is at the top of the ramp and B near the bottom.

Select Timer and set up as shown below.

Recording Wizard step 1	Recording Wizard step 2
Time and speed	Time and speed from A to B
	Enter the distance from A to B

1. Set up the apparatus as shown in the diagram above, marking a Start line for the cars.

2. Click on the Start icon.
3. Launch the Timer program and set up as above.
4. Let the first car run down the inclined plane.
5. Repeat the run several times to get a good average.
6. Repeat until all the toy cars have been tested.

## Extensions

1. Try changing the height of the inclined plane and repeating the experiment.
2. Try adding mass (plasticine) to the cars and repeating the experiment.



Cars.	Average Time from A to B.	Distance travelled.	Average speed.

## Questions

1. Why was it important to mark a starting line?
2. Which car had the fastest time?
3. Which car had the slowest time?
4. Can you offer an explanation as to what made the difference?
5. Does making the inclined plan steeper make any difference to the results?
6. Is there a pattern when comparing the different heights and the average speeds?



Sensors: Light gates  
Logger: Any EASYSSENSE

Logging time:  
Speed at A

## 19 - Measuring speeds on a runway



When a trolley or toy car moves freely down a slope, it appears to get faster as it nears the bottom. In this experiment, you will measure the speed of the trolley at different points along the runway, by moving the position of the Light gate.

The interrupt card breaks the light gate's beam. The software records the time from when the beam is broken to the time when it is unbroken. As the length of the card is given, the software can calculate speed.

Speed = Distance (length of card).

Time (taken for the card to go through the light gate).

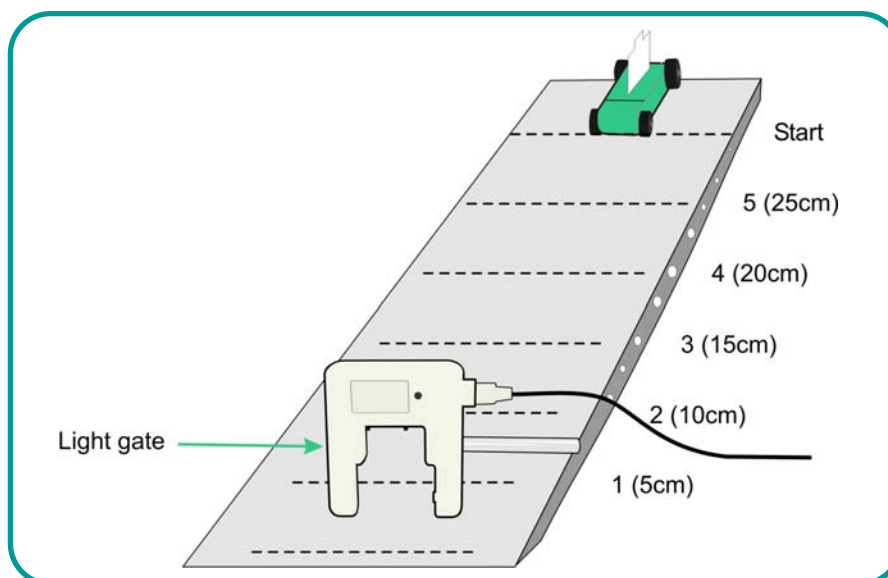

### What you need

1. EASYSSENSE logger.
2. 1 x Smart Q Light gate.
3. 1 Trolley and inclined plane OR toy car and ramp with marks at 5 cm intervals.
4. Card 3 cm long, with a marked centre point for the trolley or toy car.

## What you need to do

1. Assemble the apparatus as shown, connecting the Light gate to Input A of the logger.
2. Fix the light gate in position 1 at the bottom of the runway.
3. Do a test run to ensure that the card breaks the light gate's beam.
4. Select Timer program and set up as below.

Recording Wizard step 1	Recording Wizard step 2
Time and speed	Speed at A
	Enter the length of the card

5. Click on the start icon to begin logging.
6. Align the centre mark of the card on the trolley with the Start line and release the trolley. The speed will be shown on the screen. If any mishaps occur, stop the recording, delete the result, then repeat the recording.
7. Write down the distance between the light gate and Start line in the Comments column.
8. Place the light gate at the second position on the runway, and repeat the experiment. Remember to record the distance between the Light gate and Start line each time.
9. Repeat for positions 3, 4 and 5.



## Results

1. The table of results can be saved, printed or copied into your report document as required.
2. Display the results as a Graph (or transfer the data into a spreadsheet program) and plot an x-y graph of Speed at A (y-axis) against the reading (x-axis).

## Questions

Compare the speed values at 5cm with those at positions 2, 3, 4 etc. Is there a pattern in the way speed changes with distance?

## Extensions

Repeat the experiment with the runway adjusted to a different height. Does the shape of the graph change?

Does the mass of the trolley or car change the result? Load masses on to the trolley to find out.



Sensors: Light gates  
Logger: Any EASYSense

Logging time:  
Timing

## 20 - Acceleration due to gravity



This investigation uses a timing card and a single light gate to measure acceleration due to gravity. The timing card has two equal width segments. The Timer program measures the initial velocity as the first segment passes through the Light gate, and the final velocity when the second segment passes through the light gate. The software calculates the resulting change of velocity per second.

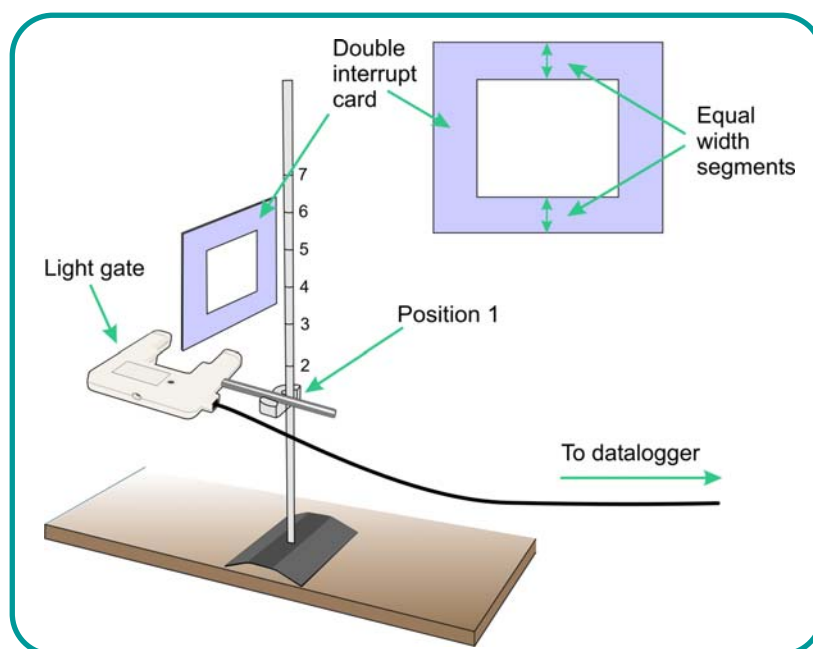

### What you need

1. EASYSense logger.
2. A Smart Q light Gate.
3. Retort stand, clamp and boss.
4. Double interrupt card.
5. Ruler (mm divisions).

### What you need to do

1. Set up the apparatus as shown, connecting the Light gate to Input A on the logger.

2. Mark 4 Start positions on the Retort stand. (Position 1 should be as close the light gate as possible without breaking the beam.)
3. Select the Timer program and set up as below.

Recording Wizard step 1	Recording Wizard step 2
Acceleration	Acceleration at A
	Length of card = length of segment e.g. 3cm

4. Click on the Start icon to start logging.
5. Hold the card in the centre and drop the timing card from Position 1.
6. Repeat 4 more times to obtain 5 results. (Stop and delete any obviously obscure measurements.)
7. Calculate the average acceleration for Position 1 and enter it into the 'Comments' column. Double click on Comments and change the title to Average Acceleration m/s/s.
8. Start logging, dropping the timing card from Position 2 to obtain 5 results.
9. Continue the experiment for each Position, and build up a table of results as shown below.

Acceleration at A				
	Position 1	Position 2	Position 3	Position 4
Average acceleration				



## Results

The results can be saved, printed or copied into your report document.

Complete the table from your results.

## Questions

1. Does the acceleration of a falling object change as it falls to earth?
2. As the timing card was dropped from different heights, the initial and final velocities measured by the software would have been different. Explain how different initial and final velocities can lead to the same calculated value of acceleration.



Sensors: Voltage  
Logger: Any EASYSense

Logging time:  
20 seconds

## 21 - Dynamo Effect



### Read

In this experiment a Voltage sensor is used to show the effect of spinning a magnet inside a wire coil – a simple dynamo.

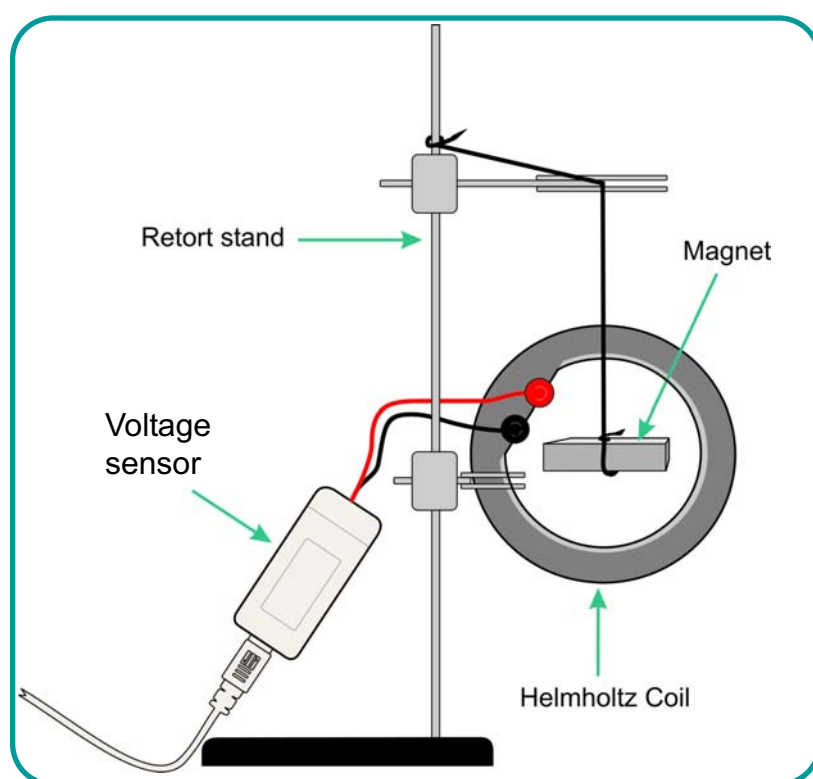

### What you need

1. EASYSense logger.
2. 1 Smart Q Voltage sensor  $\pm 1V$ .
3. 1 Wire Coil
4. 1 strong magnet suspended on a string or rubber band.

### What you need to do

1. Assemble the apparatus as shown in the diagram above, and connect the Voltage sensor to input 1.

2. Ensure that the magnet is free to spin within the centre of the coil.
3. Select Graph software and use the set up below.

Recording Wizard step 1	Recording Wizard step 2
Select a Timespan of 20 seconds	Start condition: None

4. Twist the magnet by 20 – 30 turns and hold it.
5. Click on the Start icon and release the magnet.  
(If the magnet touches the side of the coil, adjust its position, and restart data capture.)



## Results

1. The results can be saved, printed, or copied to your report document.
2. Use Add Text tool to label the start and finish of one complete cycle.

## Questions

1. What was the maximum voltage created?
2. How was the voltage related to the speed of rotation of the magnet?
3. How many revolutions did the magnet make? Explain your answer.
4. What description is given to a voltage that changes like this?



Sensors: Current  
Logger: Any EASYSense capable of Fast

Logging time:  
Fast

## 22 - Dropping a magnet through a wire coil



This simple and very fast activity with a Current sensor, introduces the need for fast data logging.

A single wire will produce a small current if it is moved through a magnetic field. The current produced is described as induced. The same effect can be produced when a magnet is moved across a wire. If the wire is coiled the effect is greater. Faraday discovered that the current produced is controlled by the speed of the magnet's movement, the strength of the magnet and the number of coils. The wire coil used in this experiment has 500 turns.

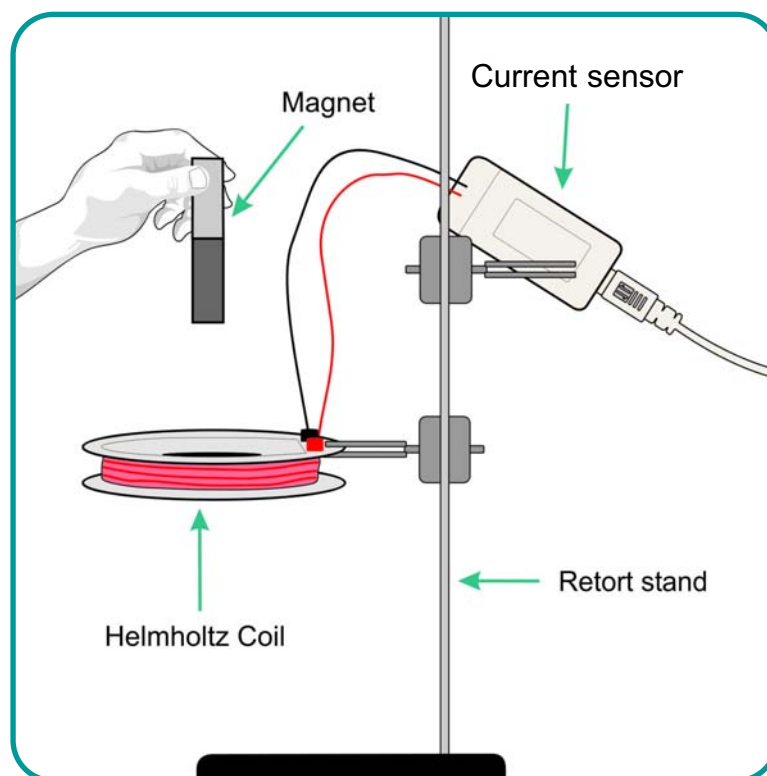

### What do you need

1. EASYSense logger.
2. 1 x Smart Q Current sensor  $\pm 100\text{mA}$ . or  $\pm 1\text{V}$  sensor.
3. 1 x Wire coil.
4. 1 strong magnet and a selection of other magnets.

## What you need to do

1. Assemble the apparatus as shown with the Current sensor connected to Input 1.
2. Make sure there is something soft for the magnet to fall on to.
3. Select Graph software and use the set up below.

Recording Wizard step 1	Recording Wizard step 2
Select intersample time of 500 microseconds	Start Condition
Select 1000 samples	Select trigger 10mA or 50mV
	Set Pre trigger 50%

**Note:** The exact trigger value will depend on the strength of the magnet, these settings had a 7cm Alnico magnet, you may need to alter this value.

4. Click on the Start icon to start the data logging.
5. Drop the magnet through the coil, taking note of which pole will enter the coil first.
6. Click on Overlay mode and click on the Start icon.
7. Drop the magnet through the coil, ensuring that the opposite pole of the magnet enters the coil first.



## Results

1. Hide the second set of data.
2. Use Values to find the maximum current value of both peaks.
3. Show the second set of data and hide the first set.
4. Use Values to find the maximum current value of both peaks.

## Questions

1. Explain why the values of the two peaks are not the same.
2. Why are the peaks opposite in direction?



Sensors: Motion  
Logger: Any EASYSense

Logging time:  
30 seconds

## 23 - Walk this way!



This investigation introduces the Motion sensor with a simple walking activity. The Motion sensor is an ultrasonic sensor. It sends out an ultrasonic pulse and times how long each pulse takes to return to the sensor. The Motion sensor can measure distances of up to 10 metres.

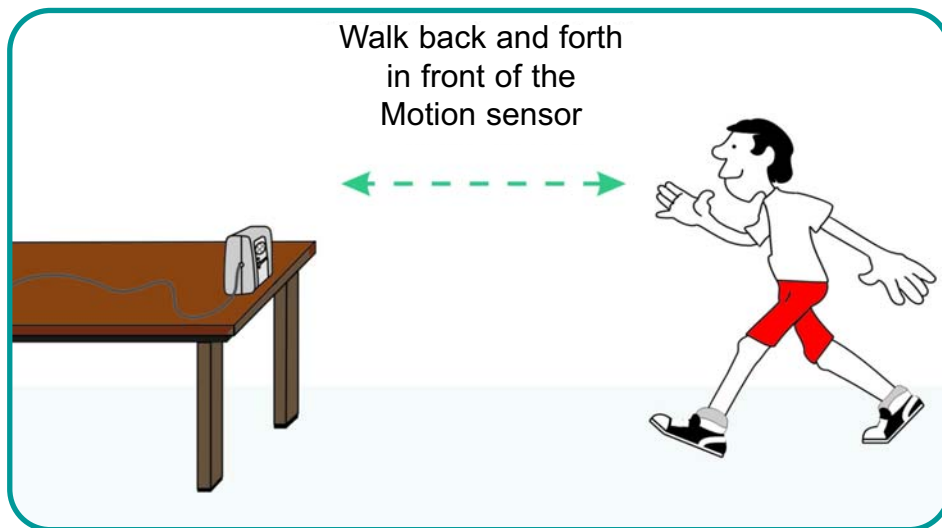

### What you need

1. EASYSense logger.
2. 1 x Motion sensor.

### What you need to do

1. Set up the Motion sensor as shown in the diagram. Make sure you have enough space to move backwards and forwards without bumping into something.
2. Select Graph program and set up as below.

<b>Recording Wizard step 1</b>	<b>Recording Wizard step 2</b>
30 seconds	Start condition : None

3. Stand several metres away from the sensor, and ask a partner to click on the start icon to start the data logging.

4. Move forwards slowly, stand still, then move fast towards the sensor, then move backwards.
5. Click on Overlay mode, then ask your partner to copy your movements, using your graph as the guide.
6. When your partner is in position, click on the Start icon to start the second graph.
7. Repeat with other volunteers. Up to 7 graphs can be produced.



## Results

1. Use Zoom to display the graphs more clearly.
2. Use Add text tool to identify whose line is whose.
3. You can select which graph to display or hide using the Select channels option with right button mouse click.
4. Use the Values tool to view the distance readings.

## Questions



1. Whose graph matched best with the original line?
2. When you move faster, how does the distance-time graph change?
3. If you stand still, what does the distance-time graph for your movement look like?



Sensors: Motion  
Logger: Any EASYSSENSE capable of Fast

Logging time:  
20 seconds

## 24 - Measuring the speed of sound in air



The Motion sensor measures distance by calculating the time for a pulse of ultrasound to travel to an object and return. We can therefore use it to calculate the speed of sound in air.

### What you need

1. EASYSSENSE logger.
2. Smart Q Motion sensor - range set to Time.
3. Smart Q Temperature sensor.
4. Measuring tape.
5. Calculator.

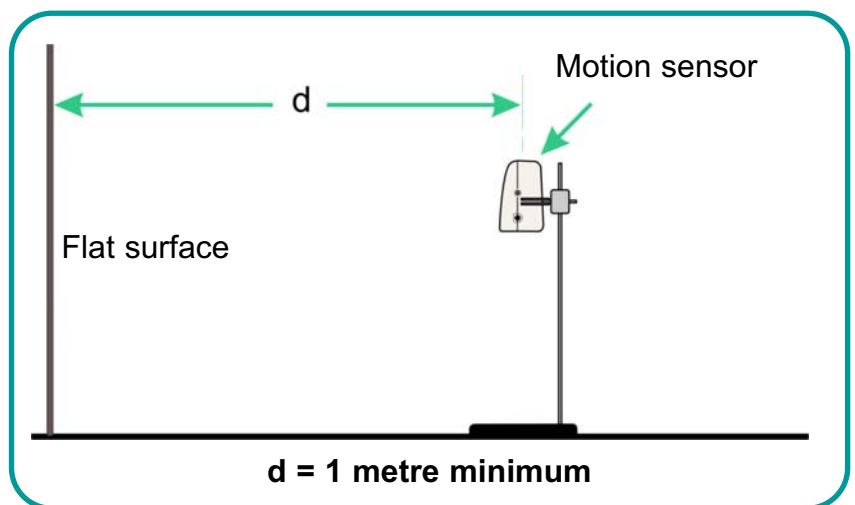

### What you need to do

#### Using EASYSSENSE Q Advanced only

1. Connect the temperature sensor and use meter to display the temperature of the room. Make a note of this value.
2. Disconnect the temperature sensor, and connect the Motion sensor.
3. Use the screen menu to change the range of the Motion sensor to Time.
4. Assemble the apparatus as shown in the diagram. The flat surface needs to be a good reflecting surface. Ensure that the face of the sensor is vertical and at least 1 metre from the flat surface.
5. Use Meter to get a reading of time (for the pulse to travel to the flat surface and back - 2 metres) This reading is in milliseconds. 6000ms is the same as .006000 seconds.
6. Using the equation, velocity = distance divided by time, use a calculator to find the velocity of sound in metres per second.
7. Use the screen menu to measure the temperature of the air.

## Using an EASYSense logger and a computer

1. Connect the Temperature sensor to the logger and select Graph software. Use Test mode to measure the temperature of the air, and make a note of this value. Disconnect the Temperature sensor.
2. Connect the Motion sensor to Input 1 and use the Sensor Config utility to set the range to Time.
3. Select a new Graph as follows:

Recording Wizard step 1	Recording Wizard step 2
Select 20ms	Select 1000 samples

4. Click on the run icon to start the data logging.



1. Use the Value tool to find the maximum and minimum reading, ignoring any blips. Use these to define an average value.
2. Remember the distance the pulse has travelled is 2 metres.
3. Use the equation:
4. Velocity = Distance divided by Time to obtain a result in milliseconds (ms).
5. To obtain speed (velocity) of sound per second, put a decimal point and 2 zeroes in front of your time value.  
e.g. 5550 ms = .005550 seconds or:

$$v = \frac{2d}{t} \text{ ms}^{-1}$$

$$t \times 10^{-6}$$

### Extension:

The value of velocity of sound increases with temperature. At 0°C the velocity of sound = 331.3 metres per second.

The velocity of sound increases at 0.607 metres per second per degree Celsius.

(Ref Kaye and Laby)

At 24 °C speed/velocity of sound = 331.3 + 24 x 0.607 = 345.9 metres per second.

Compare your results with the standard.



Sensors: Polar Heart Rate  
Logger: Any **EASYSSENSE**

Logging time:  
5 minute

## 25 - Heart rate and exercise



This activity introduces the Polar Heart Rate Exercise Sensor and is an opportunity to find out more about heart rate and how it is affected by exercise. This sensor lends itself to use with a remote data logger, such as **EASYSSENSE Q** or **EASYSSENSE Advanced**.



### What you need

1. **EASYSSENSE** logger.
2. 1 x Smart Q Polar Heart Rate sensor and Polar Heart Rate transmitter belt.

### What you need to do:

1. Put on the Polar Heart Rate transmitter belt around the chest.
2. Connect the Polar Heart Rate sensor to the **EASYSSENSE** logger.
3. Select Graph program and use Test mode to check that the sensor is receiving a signal from the belt's transmitter. (Is the red LED flashing?) (Alternatively, select Meter to view the values on the data logger's screen).
4. Staying within 1 metre range of the Polar Heart Rate sensor, use a Stepper, an Exercise bike or Rowing machine.

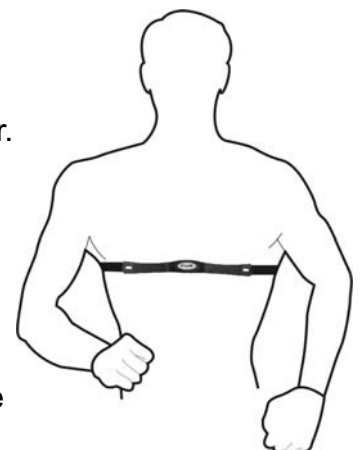

- Click the New Graph icon to set up a new recording using the set up below.

Recording Wizard step 1	Recording Wizard step 2
Select a Timespan of 5 minutes	Start condition: None

- Click on the Start icon to start data logging. (Alternatively use a remote data logger and select EasyLog).
- Start exercising for 5 minutes.



## Results

Use the Values tool to find out the highest heart rate measurement and the lowest.

## Questions



- What is your resting heart rate?
- By how much did your heart rate increase when you were exercising.

## Extension Activity

- Find out about target zones.
- Extend the data logging period to record recovery rate as well as the changes to heart rate during exercise.
- Find out about fitness levels.

**Note:** The Target Zone can be calculated using the Karvonen formula. This take into account a person's fitness level by incorporating their morning resting heart rate (MRHR).

The morning resting heart rate is found by taking a reading for 3 days, and finding the average. (MRHR).

When checked periodically, this number should stay steady, or even go down if the person is becoming fitter. A raised number could mean one or more of the following:

- That they have not recovered from a hard workout the day before.
- That they need more rest.
- That their body has begun to fight off an oncoming illness.

### The Target Zone is calculated as follows:

Max heart rate (220) minus age = estimated maximum heart rate (HRMx) HRMx minus MRHR = multiplier.

**To find a personal target zone:**

Multiplier x .60 +MRHR = ( ) 60% limit number

Multiplier x .70 + MRHR = ( ) 70% limit number

**Example:** Lee is 31 years old and his morning resting heart rate is 68

$$220 - 31 = 189$$

$$189 - 68 = 121$$

$$121 \times .60 = 72.6 + 68 = 141$$

$$121 \times .70 = 84.7 + 68 = 153$$

His 60 – 70% target zone would be 141 - 153

**Notes:**

---

**Notes:**

---

**Notes:**

---